

3

3

3

К

---





Рис. 1.



Рис. 2.

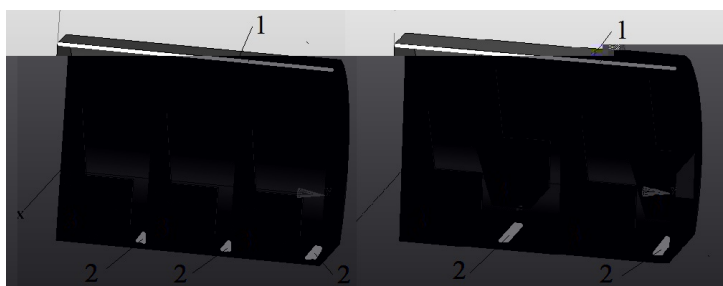

$$T_{cp} = 21 \text{ } ^\circ\text{C}$$



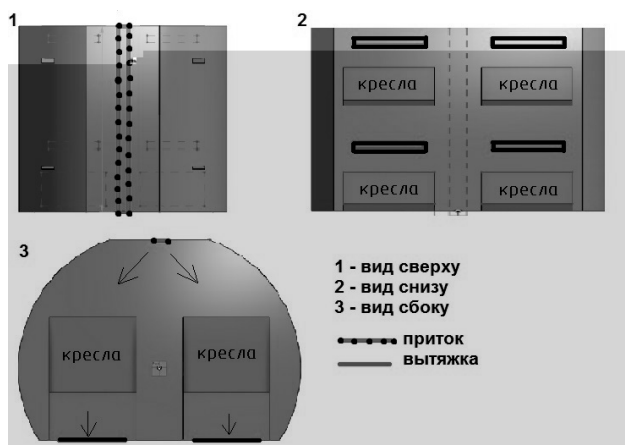
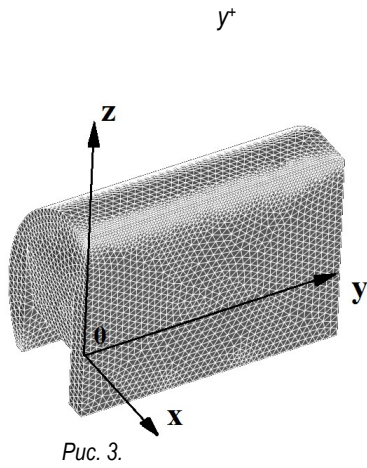

Рис. 4.1.



Рис. 4.2.

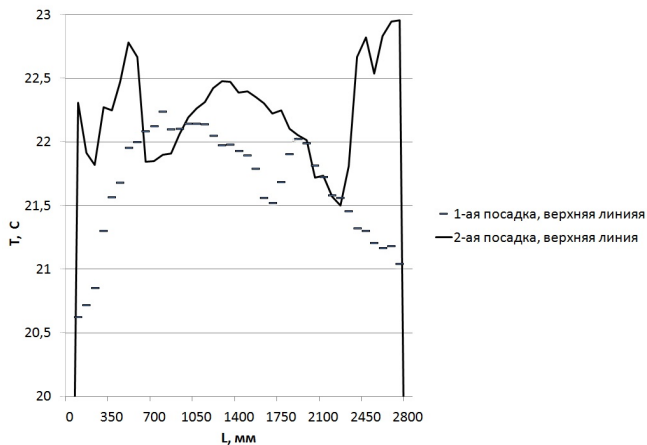

Рис. 5.1.

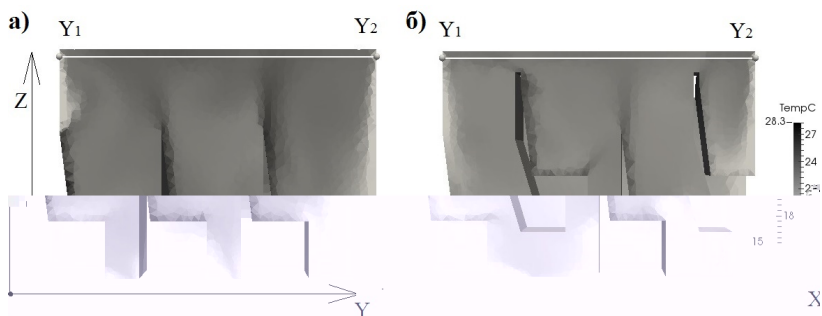

Рис. 5.2.

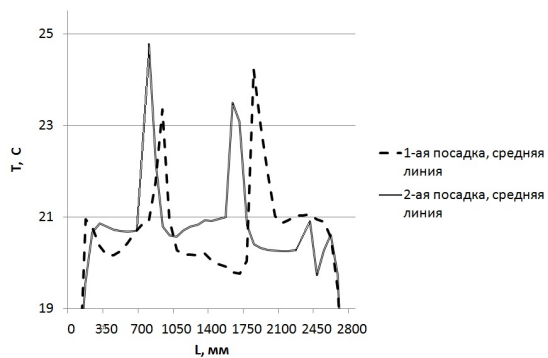

Рис. 6.1.

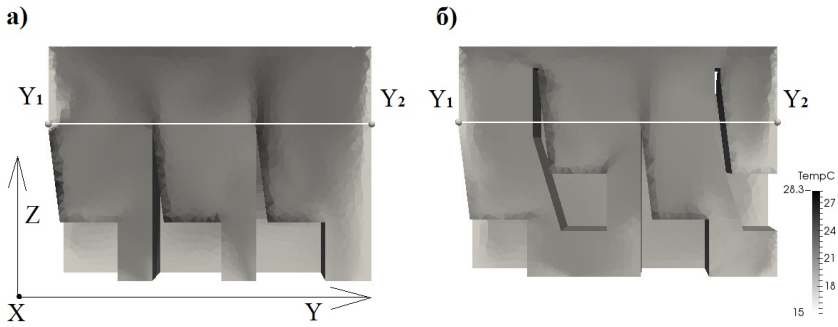

Рис. 6.2.

3

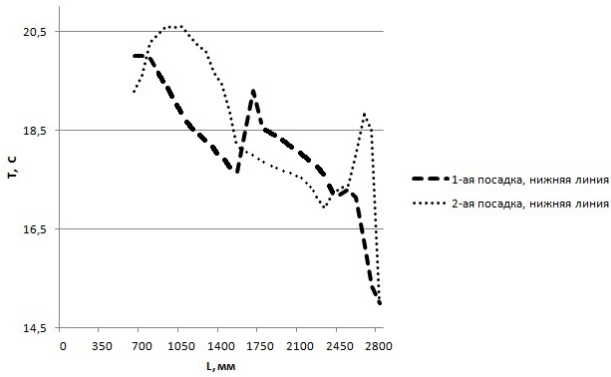
3

3

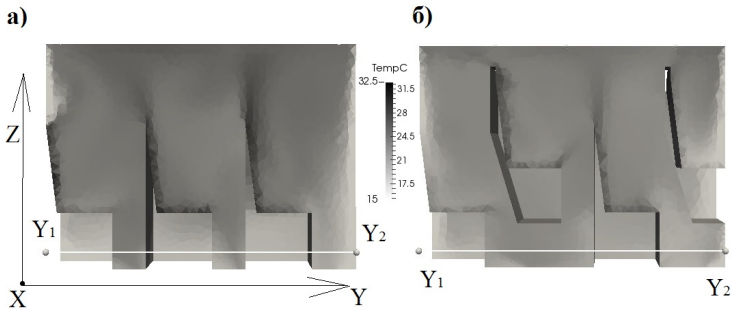
κ

---